

## MODELING THE EFFECTS OF THE VORTEX FINDER HEIGHT ON PRESSURE DROP IN THE CYCLONE USING COMPUTATIONAL FLUID DYNAMICS

**Maribel R. Valverde, José R. Coury, José A. S. Gonçalves.**

*Chemical Engineering Department,  
Federal University of São Carlos Rod. Washington Luiz, km. 235, CEP 13 565-905 –  
São Carlos – SP – Brazil,  
valverderamirez@hotmail.com, jcoury@ufscar.br; jason@ufscar.br  
[http://www2.ufscar.br/interface\\_frames/index.php?link=http://www.ppeq.ufscar.br/](http://www2.ufscar.br/interface_frames/index.php?link=http://www.ppeq.ufscar.br/)*

**Keywords:** Cyclone, Pressure Drop, Turbulent Kinetic Energy, Height of the Vortex Finder.

**Abstract.** Simulations using computational fluid dynamics techniques were performed intending to analyze the effect of the height of the vortex finder on the pressure drop of cyclone separators. Three cyclones were studied with 0.25 m diameter, varying the height of the vortex finder at 0.122, 0.367 and 0.612 m. The experimental data used in validation of the simulations were obtained from the literature. The modeling was done in 3D transient. K-epsilon and Reynolds stress models are used to simulate a turbulence inside the cyclone. Profiles and isosurfaces show a pressure drop and turbulent kinetic energy. The pressure drop decreases with increasing height of the vortex finder. The average deviation between the simulation results and experimental data is less than 7% using RSM turbulence model and 13% using RNG K-epsilon turbulence model.

## 1. INTRODUCTION

Cyclones are gas-solid separation devices. In its most common form, a gaseous stream containing particulates enters tangentially in a body that consists in a cylinder followed by a conical section. Due to the difference in density between the phases and due to the centrifugal force, the particles move across the gas towards the cyclone walls, while the gas moves in swirl. The particles can hit and adhere to the walls or slide on the surface until they reach the hooper, where they are removed from the system; the gas eventually reverses its initial downward movement and exits the cyclone through the vortex finder in the top of the device. Although the device is mechanically simple, the flow in its interior is mathematically complex due to the swirling motion and anisotropic turbulence (Chuah *et al.*, 2009).

The vortex finder (the gas exit duct) penetrates the body of the cyclone a height  $S$ , as shown in Figure 1. It is necessary to prevent a short circuit between the gas inlet and outlet, as well as to impose an initial downward movement to the gas. An increase in the height of the vortex finder will cause an increase in particle residence time and therefore affect the collection efficiency of the cyclone. However, if the downward end of the vortex finder reaches the conical section some coarse particles can be resuspended, causing a diminution of the efficiency. The ideal height of the vortex finder depends on the size distribution of the particles and the cyclone geometry (Fernandez *et al.*, 2008).

The pressure drop in a cyclone is considered one of the most important parameter of performance from the economical standpoint (Hoffmann and Stein, 2002). The pressure drop determines the energy requirements and therefore the operational cost of the device. It is defined as the difference between the inlet and outlet pressures. Pressure drop is a function of the cyclone dimensions, operational conditions such as gas velocity and friction. The most important loss of energy occurs at the vortex finder, and it can be up to one order of magnitude greater than the pressure drop due to other reasons. (Hoffmann and Stein, 2002; Ficici *et al.*, 2010; Elsayed and Lacor 2010; chuah *et al.*, 2009).

The purpose of this paper is to evaluate whether computational fluid dynamics (CFD) can predict satisfactorily the pressure drop in a cyclone as a function of vortex finder height. The simulation results are compared with experimental results of Scarpa, 2000.

The pressure drop was simulated in three cyclones with different vortex finder heights (0.122, 0.336 and 0.612 m).

## 2. NUMERICAL MODEL

An appropriate choice for the representation of the turbulence in a cyclone is essential for the correct prediction of its pressure drop. Both the RNG  $\kappa$ - $\varepsilon$  and the RSM turbulence models have been able to reproduce reasonably the pressure drop in cyclones, although usually the RSM model has been more accurate (Chuah *et al.*, 2006). In this study, the turbulence was modeled the RSM turbulence models. The Reynolds Averaged Navier-Stokes equations (RANS), where the Reynolds tensor was calculated by the Reynolds Stress Model (RSM). In RANS, the solution for the instantaneous variables is made by their decomposition into the sum of a time averaged variable and a fluctuation variable. Thus, the instantaneous velocity is given by:

$$u_i = \bar{u}_i + u_i' \quad (1)$$

Where  $\bar{u}_i$  and  $u_i'$  represent the time averaged velocity and the fluctuation velocity, respectively, for the direction coordinates  $i=1, 2, 3$ ).

Substituting Equation (1) into the Navier-Stokes equations and performing a time-averaged operation, we obtain, for incompressible turbulent flows, the following equations:

$$\frac{\partial u_i}{\partial x_i} = 0 \quad (2)$$

$$\frac{\partial u_i}{\partial t} + u_j \frac{\partial u_i}{\partial x_j} = -\frac{\partial p}{\partial x_i} + \frac{\partial}{\partial x_j} \left[ \mu \left( \frac{\partial u_i}{\partial x_j} + \frac{\partial u_j}{\partial x_i} + \frac{2}{3} \delta_{ij} \frac{\partial u_i}{\partial x_j} \right) \right] + \frac{\partial}{\partial x_j} (-\rho \overline{u'_i u'_j}) \quad (3)$$

The last term on the right hand side of Equation (3) represents the Reynolds tensor. The Reynolds Stress Model resolves transport equations for each component of this tensor:

$$\frac{\partial}{\partial t} (\rho \overline{u'_i u'_j}) + \frac{\partial}{\partial x_k} (\rho u_k \overline{u'_i u'_j}) = D_{ij} + P_{ij} + \pi_{ij} + \varepsilon_{ij} + S \quad (4)$$

The two terms on the left hand side are the local temporal derivative and the transport convective term. The five terms in the right hand side are:

Diffusive term:

$$D_{ij} = -\frac{\partial}{\partial x_k} \left[ \rho \overline{u'_i u'_j u'_k} + (\overline{P' u'_j}) \delta_{ik} + (\overline{P' u'_i}) \delta_{jk} - \mu \left( \frac{\partial}{\partial x_k} \overline{u'_i u'_j} \right) \right] \quad (5)$$

Production term:

$$P_{ij} = -\rho \left[ \overline{u'_i u'_k} \frac{\partial u_j}{\partial x_k} + \overline{u'_j u'_k} \frac{\partial u_i}{\partial x_k} \right] \quad (6)$$

Pressure term:

$$\pi_{ij} = P \left( \frac{\partial u'_i}{\partial x_j} + \frac{\partial u'_j}{\partial x_i} \right) \quad (7)$$

Dissipation term:

$$\varepsilon_{ij} = -2\mu \overline{\frac{\partial u'_i}{\partial x_k} \frac{\partial u'_j}{\partial x_k}} \quad (8)$$

Source term:  $S$

Pressure drop is calculated by the difference between static pressure in the inlet and outlet of the cyclone:

$$\Delta P = P_{inl} - P_{out} \quad (9)$$

For comparison purposes, simulations using the k- $\varepsilon$  RNG model were also performed.

The static pressure at the inlet is uniformly distributed, as there is no swirl movement yet, and therefore can be easily measured by an orifice at the wall. On the other hand, the static pressure at the outlet is not uniform, being greater at the wall and smaller in the center of the duct. This occurs because the swirl movement of the gas stores dynamic pressure (Chen and Shi, 2007). In this work the outlet average static pressure was calculated by the average of the static pressure in all the element faces contained in the outlet surface.

### 3. CONDITIONS OF THE SIMULATIONS

The geometry of a typical cyclone with tangential entry can be characterized by a set of dimensions as illustrated in Figure 1. These dimensions are: diameter of the cylindrical section ( $D$ ), total height of cyclone ( $H$ ), height of the conical section ( $H_c$ ), diameter at the end of the conical section ( $D_d$ ), vortex finder diameter ( $D_x$ ), height of the vortex finder in the

interior of the cyclone ( $S$ ), height of the gas inlet rectangular duct ( $a$ ), width of the gas inlet duct ( $b$ ). The dimensions utilized in this work are shown in [Table 1](#).

The geometry was generated using the software GAMBIT<sup>®</sup> version 2.4.6. The mesh consisted primarily of hexahedral elements. For each geometry, meshes of different densities were generated for the purpose of establishing mesh independency. From this analysis, it was concluded that approximately 90,000 cells were sufficient for securing a mesh independent solution.

In this work the particulate phase was considered dilute, and, as such, does not contribute significantly to the gas phase pressure drop ([Crowe et al., 1998](#)). In this way, the flow could be considered single phased, avoiding the complexity of the Euler-Euler multiphase algorithms which are more justifiable for denser flows. Air in ambient temperature and pressure conditions was the fluid utilized. The boundary conditions were:

- Inlet velocity = 10.2 m/s,
- Outlet relative pressure = 0 Pa (atmospheric),
- Turbulence intensity at inlet = 3.5%,
- Wall = non-slip,
- Temperature = 25 °C,
- Gravity = (0, 0, -9.81) m/s<sup>2</sup>.

The simulation was made using the software FLUENT<sup>®</sup> version 12.0.16. The turbulence model used was RSM. The equations were solved using the finite volume method. The discretization schemes were: PRESTO for the pressure and QUICK for the momentum. Pressure-velocity coupling used the SIMPLE algorithm. The simulation was assumed to converge when the residual difference was smaller than  $10^{-4}$  for all variables. The simulation was transient, with a total time of 1s and a time step  $5 \times 10^{-4}$ .

The strategy used was to simulated first in the permanent regime, using a standard  $\kappa$ - $\varepsilon$  model. Once this simulation converged, the turbulence model was changed to the RNG  $\kappa$ - $\varepsilon$  and the simulation was allowed to converge once more. The obtained solution was used as the initial solution for the transient simulations with the RSM turbulence model. A computer with a quad-core Intel Core processor, 6 GB RAM and 64 bit operational system was used.

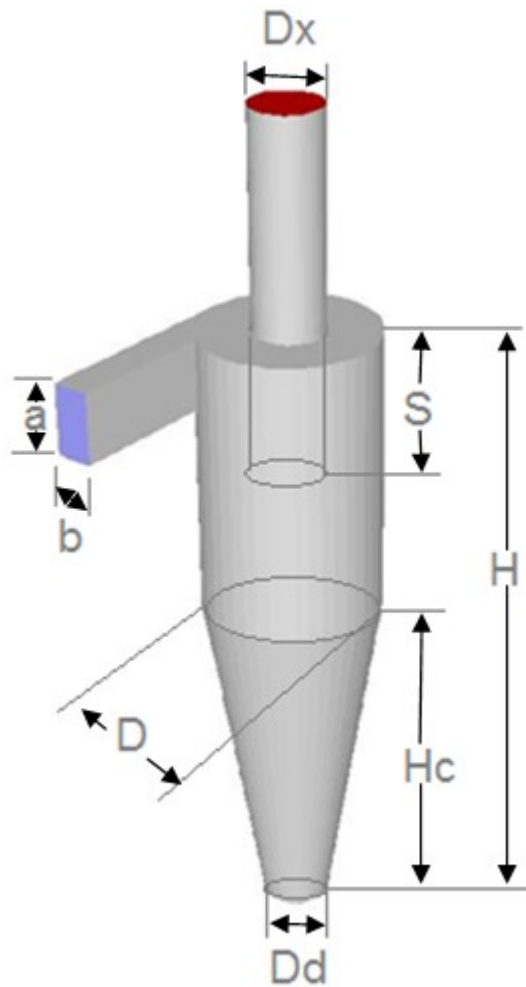

Figure 1: Characteristic dimensions of a tangential inlet cyclone.

Constant dimensions in all three cyclones (m)	D	0.245
	H	0.875
	H <sub>c</sub>	0.480
	D <sub>d</sub>	0.090
	D <sub>x</sub>	0.098
	a	0.098
	b	0.051
Vortex finder height (S) (m)	Cyclone 1	0.122
	Cyclone 2	0.367
	Cyclone 3	0.612

Table 1: Dimensions of the cyclones used in this work (m).

#### 4. RESULTS AND DISCUSSION

The pressure drop results obtained are shown in Table 2. The pressure drop obtained using RNG  $\kappa$ - $\epsilon$  turbulence model report deviated from the experimental data 12.40% in average, and using RSM turbulence model report deviated from the experimental data 6.69% in average. Numerical and experimental data show the same variance.

A pressure drop to increase up to a certain point with the increase of the vortex finder height and then decrease with further increase of the height was also predicted successfully by the simulations. However, it should be observed that the model consistently predicted a higher pressure drop than the experimental.

Quantity		Cyclone 1	Cyclone 2	Cyclone 3
Height of <i>vortex finder</i> (m)		0.122	0.367	0.612
Experimental pressure drop (Pa)		491.98	534.46	456.01
Simulated with RNG $\kappa$ - $\varepsilon$ turbulence model	Pressure drop (Pa)	464.37	498.05	569.08
	Difference between experimental and simulated (%)	5.61	6.81	24.79
Simulated with RSM turbulence model	Pressure drop (Pa)	468.86	502.65	499.02
	Difference between experimental and simulated (%)	4.69	5.95	9.43

Table 2: Pressure drop: Experimental (Scarpa, 2000) and simulated pressure drop.

The profile of static pressure inside the cyclone is shown in Figure 2, for the three cyclones. The profiles are typical: the pressure is greater near the walls and decreases with the radius to a minimum value in the central axis. The pressure gradient is greater in the radial direction, in comparison with the axial and tangential directions. It can be seen that the modification of the vortex finder height affects the pressure profile. The region of negative pressures is kept always below the vortex finder end. The pressure drop obtained in cyclone 1 and 2 follows the same behavior observed by Ficici *et al.*, 2010. In cyclone with vortex finder longer,  $S$ , more than the cylindrical body, the turbulent intensity is rather weak and has led to re-entrained flow into the vortex finder, hence, increasing the axial velocity (Chuah *et al.*, 2009). That could be the reason for the decrease the pressure drop in the cyclone 3.

Through Figure 3 it is possible to visualize the regions of maximum and minimum of the turbulent kinetic energy. This energy is greater near the vortex finder inlet. This behavior is typical because contraction of radius (Yan *et al.*, 2000). Is observed high instability and high turbulent near the axis and low turbulent near the wall (Figure 3 and Figure 4). Similar radial profile was observed in cyclone with conventional vortex finder by Abdullah *et al.*, 2003. Figure 4 show the turbulent energy kinetic in different proportions (Cyclone 2 > Cyclone 1 > Cyclone 3)

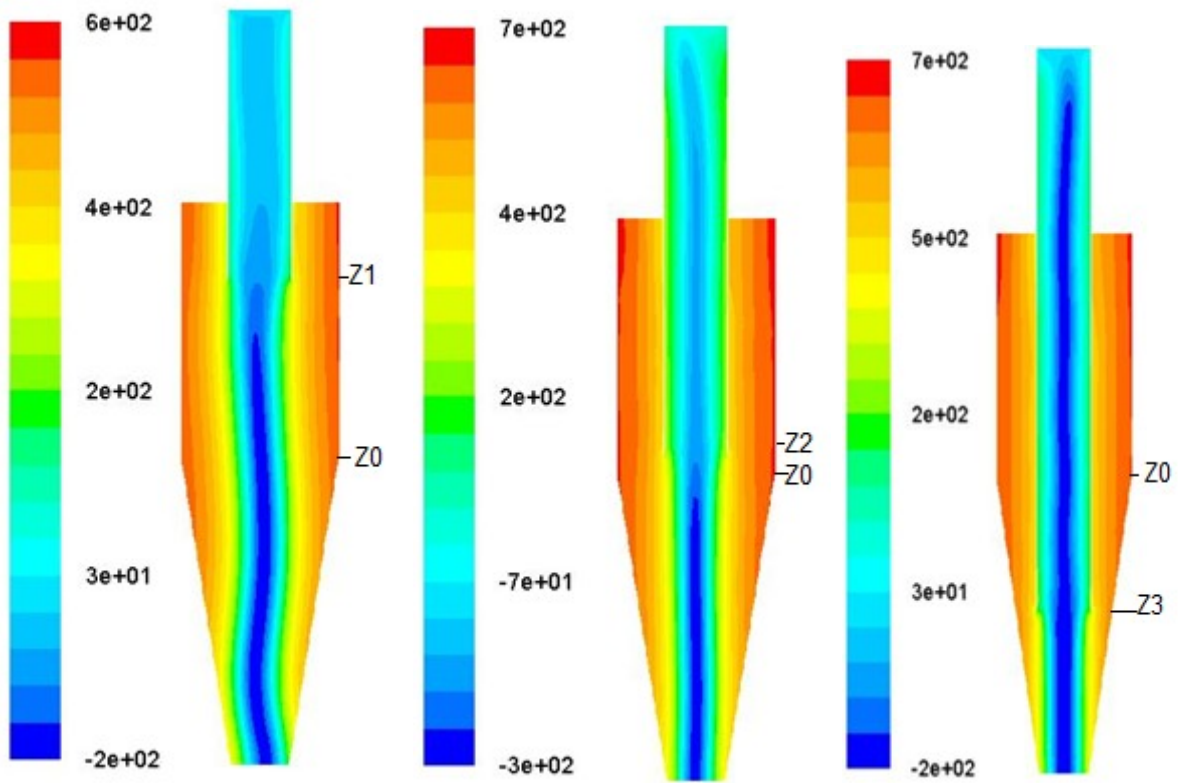

Figure 2: Static pressure drop profile (Pa). Cyclone1, cyclone 2 and cyclone 3.

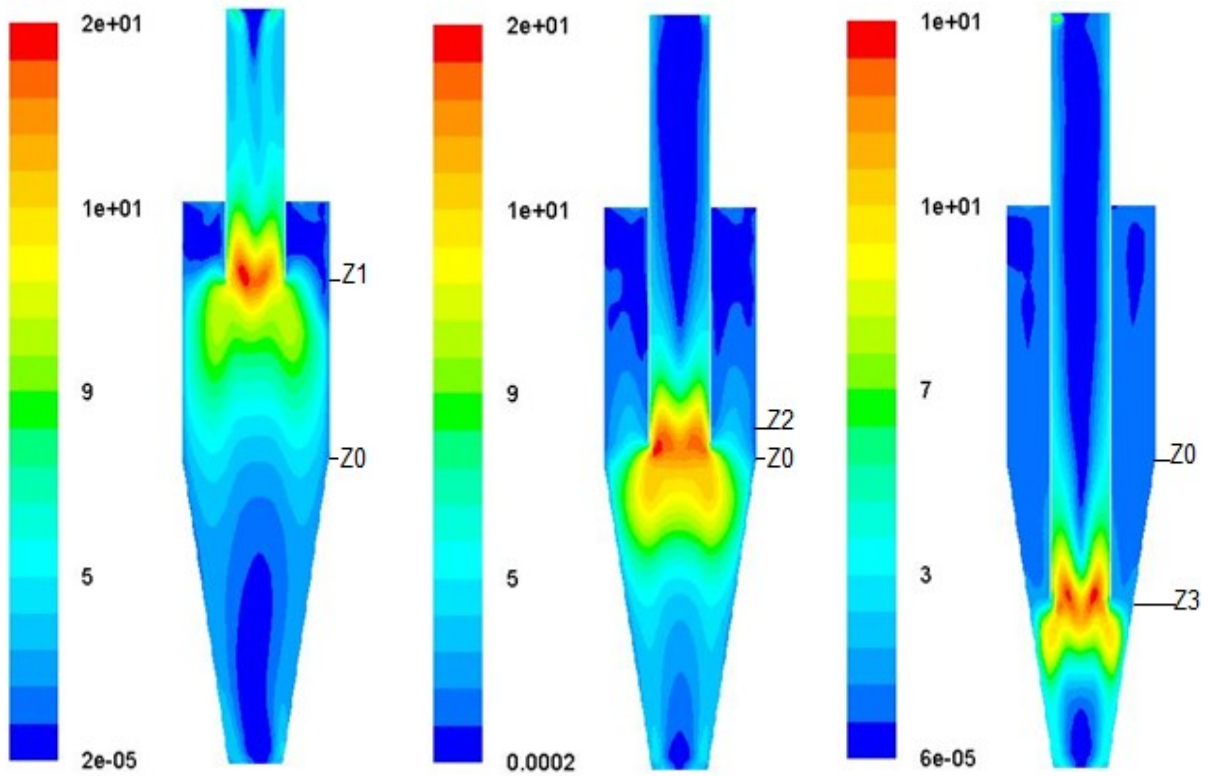

Figure 3: Turbulent kinetic energy ( $m^2/s^2$ ) profile. Cyclone 1, cyclone 2 and cyclone 3.

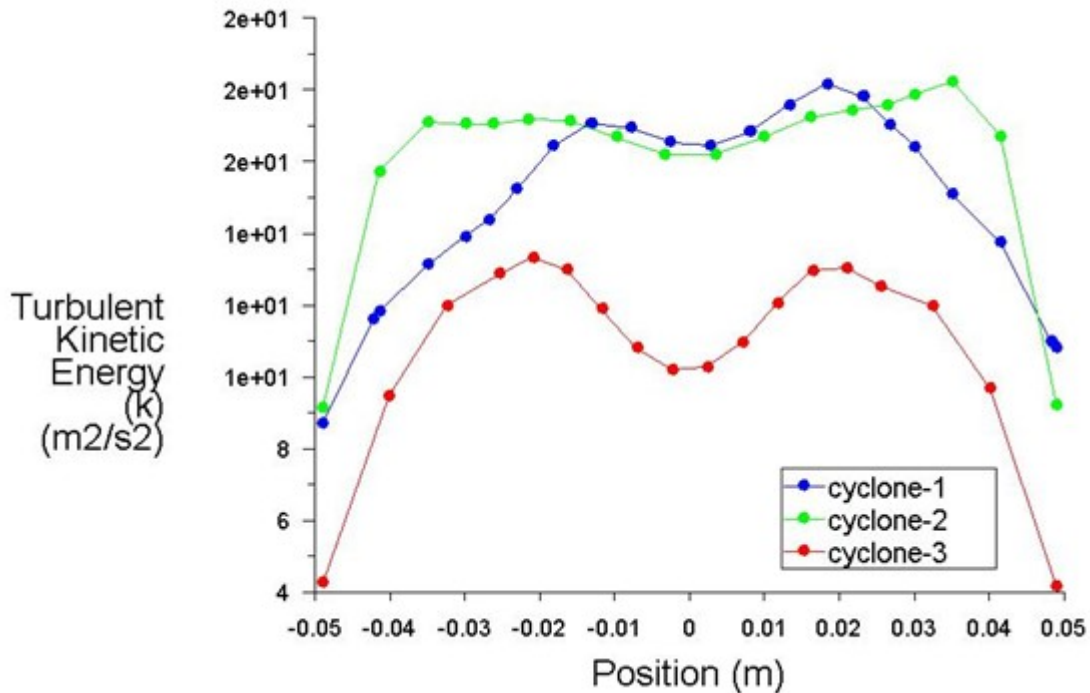

Figure 4: Radial profile for the turbulent kinetic energy ( $\text{m}^2/\text{s}^2$ ) cyclone 1 ( $Z_1=0.273$ ), cyclone 2 ( $Z_2=0.028$ ) and cyclone 3 ( $Z_3=-0.217$ ) (for  $Z_0=0$ ).

## 5. CONCLUSIONS

The numerical data obtained through computational fluid dynamics show that:

- CFD simulations can reproduce with success the pressure drop in cyclones. In this study we used RNG  $\kappa$ - $\epsilon$  and RSM model of turbulence. With RNG  $\kappa$ - $\epsilon$  turbulent model the maximum deviation was 24.79% and with RSM turbulent model the maximum deviation was 9.43%. The RSM model of turbulence can be recommended for the study of the flow in cyclones.
- Increasing the height of the vortex finder increases the pressure drop. If the height of the vortex finder is greater than the height of the cylindrical surface, the pressure drop decreases.
- Varying the height of the vortex finder, varying the total turbulent kinetic energy and varying the pressure drop in cyclone with tangential inlet.

## 6. ACKNOWLEDGMENTS

The authors are grateful to CNPq for the financial support which made this study possible.

## REFERENCES

- Abdullah M. Z., Husain Z. and Fraser S. M., Application of deswirl device in cyclone dust separator, 20, 203 - 216, 2003.
- Chen J. and Shi M., A universal model to calculate cyclone pressure drop, *Power Technology*, 171, 184 - 191, 2007.
- Chuah L. A., Gimbin J. and Thomas S. Y., A CFD of the effect of cone dimension on sampling aerocyclones performance and hydrodynamics, 162, 126 - 132, 2006.



- Chuah L. A., Gimbin J., Thomas S. Y. and Fakhru'l-Razi A., A CFD analysis on the effect of vortex finder and cylindrical length on cyclone hydrodynamics, *Journal The Institution of Engineers*, 71, 2, 2009.
- Crowe C. T., Sommerfeld M. and Tsuji Y., *Multiphase flows with droplets and particles*, CRC Press, 1998.
- Elsayed K. and Lacor C., The effect of vortex finder diameter on cyclone separator performance and flow field, *V European Conference on Computational Fluid Dynamics, ECCOMAS CFD*, 2010.
- Fernandez M. L., Gutiérrez L. A., Mahamud M. M. and Bueno L. J., Vortex finder optimum length in hydrocyclone separation, *Chemical Engineering and Processing*, 47, 192-199, 2008.
- Ficici F.; Ari V. and Kapsiz M., The effects of vortex finder on the pressure drop in cyclone separators, *International Journal of the Physical Sciences*, 5, 804-813, 2010.
- Hoffmann A.C. and Stein L.E., *Gas Cyclones and Swirl Tubes*, 2nd ed., Springer, 2002.
- Scarpa J. D., *Influência de características geométricas no desempenho de um ciclone*, Dissertação de Mestrado, Universidade Federal de São Carlos, Brazil, 2000.
- Yan L., Vastistas G. H. and Lin S., Experimental studies on turbulence kinetic energy in confined vortex flows, *J. of Thermal Science*, 9, 10-21, 2000.