

## SIMULATED ANNEALING FOR THE OPTIMIZATION OF TRUSSES

Herbert M. Gomes<sup>a</sup>, Franklin S. Ferreira<sup>b</sup>

<sup>a</sup>*Professor of Applied Mechanics Group GMAp, Universidade Federal do Rio Grande do Sul, Rio Grande do Sul, R.. Sarmento Leite, 425, sala 202, 2º. andar, 90050-170, Porto Alegre, Brasil, <http://www.mecanica.ufrgs.br/gmap>, e-mail: [herbert@mecanica.ufrgs.br](mailto:herbert@mecanica.ufrgs.br)*

<sup>b</sup>*M.Sc. candidate, Post Graduate Course in Mechanical Engineering, Universidade Federal do Rio Grande do Sul, Rio Grande do Sul, R.. Sarmento Leite, 425, sala 202, 2º. andar, 90050-170, Porto Alegre, Brasil, <http://www.mecanica.ufrgs.br/gmap>, e-mail: [franksfbr@yahoo.com.br](mailto:franksfbr@yahoo.com.br)*

**Keywords:** Simulated Annealing, Heuristic Algorithm, Stochastic Optimization.

**Abstract.** The Simulated Annealing (SA) Technique belongs to a Stochastic Optimization class of algorithms. This technique has been used as a soft computing technique in hard optimization tasks, such as, electronic components allocation, spatial representation of chemical compounds and Traveling Salesman type problems, for a long period. This technique is based on the mathematical description of the experimental cooling technique developed to design stronger crystals (like glass) and metals. In this paper this technique was implemented on a Matlab ([Matlab, 2001](#)) environment and applied to simple and difficult parametric truss optimization problems with constraints in displacements and stresses. The examples were selected in order to compare results with those presented by related literature. SA Technique performance is compared with those obtained with other heuristic methods like the Genetic Algorithm (GA) and with gradient based Mathematical Programming Algorithms, such as Sequential Quadratic Programming (SQP). The presented results show some disadvantages regarding the computational cost using the SA Technique, nevertheless the final results show better or similar accuracy than the ones obtained with the other methods.

## 1 INTRODUCTION

The Simulated Annealing is a Technique that has attracted attention due to its application to large optimization problems, especially those where global optimum are hidden among several 'worst' local optimum. For practical purposes the Simulated Annealing has solved the well-known traveler-salesman problem where a traveler salesman has to visit 'N' cities at most once in an economical way (tracking the small path). Other heuristic methods have been used with success as well. The SA Technique has been applied with success to design complex integrated circuit boards. The set of hundreds of circuit components in a board is optimized in such a way that the interference between tracks is minimized. Surprisingly the algorithm implementation is relatively simple. Those previously mentioned applications are combinatorial optimization problems. In such cases, as usual, there is an objective function to be optimized; however the search space is not an N dimensional space of continuum variables. On the contrary, the search space is finite and discrete but very large, as the set of the sequence of visited cities or the possibilities of circuit block allocation. The number of possible solutions in the search space is exponentially large enough to prevent any exhaustive searches be worth. In addition, as the search space is discrete, any definition of derivatives is senseless (as the intuition to use the gradient descent methods).

The use of Simulated Annealing is very diverse like in structural integrity evaluation (Carrillo, 2007), optimization of statistical function (Goffe, 1994), but in general it is used as an global optimization tool.

The optimization of trusses using heuristic algorithms was subject of several papers (Hasançebi, 2002a, 2002b; Coello, 2000; Deb, 2001 ). Particularly, in his work, Hasançebi (2002a) reformulated the working mechanism of the Boltzman parameters to accelerate and enhance the general productivity of the SA Technique, and new methodology are proposed to evaluate the two new parameters introduced (the weighted and critical Boltzman parameters) and some results were compared with those that existed in the literature.

## 2 BRIEF REVIEW OF THE SIMULATED ANNEALING TECHNIQUE

The core of the Simulated Annealing Technique is the thermodynamic analogy, specifically in the way the liquids frozen and crystallized or metals anneal as they get cold. At high temperature, as happens in liquids, the molecules move freely between each other. If the liquid is slowly cooled, the thermal mobility is lost. The atoms are often able to align themselves and a pure crystal that is completely aligned at the least energy configuration is formed. Such crystal presents a minimal energy level for the material. Surprisingly, minimal energy states are found naturally. In fact, if a liquid metal is suddenly cooled and not annealed it does not reach such states, in the opposite it transforms in an amorphous polycrystalline with an energy state higher than those slowly cooled. Thus, the essence of the method is the slowly cooling, allowing the re-distribution of the atoms and molecules as they loose mobility. This is the technical definition for annealing and it is essential to assure that the less energy state will be reach. Although this analogy is not perfect, this avoids some problems like those associated to the gradient descent search.

In the molecule level, the well-known Boltzman probability distribution is defined as Eq.(1),

$$P(\Delta E) = e^{-\frac{\Delta E}{kT}} \quad (1)$$

and it expresses the idea that a system thermodynamically in equilibrium at temperature  $T$  has

its own energy probabilistically distributed in different energy levels. Even at low temperature, there is a little chance that the system was in a high energy state. So, there is a chance that the system could leave from a local minimum, crossing higher energy levels in order to find a better solution far from original position. The Boltzman constant  $k$  is the constant that in nature relates the temperature with energy.

In other words, the system make ascents as descents, but at low temperature, uphill excursion are less probably that at higher temperature. [Metropolis \(1953\)](#) and co-authors firstly incorporated those principles on numerical estimates. First it was proposed a series of options and a thermodynamically system was assumed to change its energy state configuration from  $E_1$  to  $E_2$  with a probability  $p = \exp(-(E_2 - E_1)/kT)$ . It should be highlighted that if  $E_2 < E_1$  this probability is not evaluated. In this case the probability is attributed to the unity  $p = 1$ . In this case the system always takes this option, i.e., it changes its energy level to a lower one. The whole picture is to take always descent steps and sometimes take ascent steps and these rules became known as Metropolis Algorithm. In order to use the Metropolis Algorithm to different non-thermodynamic systems, some adjustments should be taken into account.

1. It is necessary a precise description of all possible system configurations.
2. A random generator of feasible “perturbed” system configurations should be available.
3. It is necessary to define an objective function  $E$ , similar to the energy function, which will be minimized by the procedure.
4. A control parameter  $T$ , similar to the temperature, and an Annealing Scheme must be chosen in order to indicate how temperature decreases with time. Some stop criteria should be elected, such as the maximum allowed number of system perturbations, number of iterations with no change in the objective function  $E$ , related to a system configuration, to be considered as an optimum.
5. A dimensional parameter  $k$ , similar to the Boltzman constant, should be used to adjust the probabilities of acceptance for uphill climbs. This parameter will depend on the units of the Energy function as well as the units of the Temperature parameter.

The proof of the Simulated Annealing Technique as a global optimization Algorithm can be found everywhere such as in [Delyon \(1988\)](#), [Locatelli\(2000\)](#), [Ingber\(1989\)](#) and [Rajasekaran \(1990\)](#). It is not intended to develop or to show the proof in this paper, but it can be said that most of the proofs are based on Markov Chain models and the Theory of Probability.

## 2.1 Algorithm Scheme for Function Minimizations

In the [Figure 1](#) it is described the way the Annealing Algorithm behaves for function minimizations with a single variable. In this case  $x_i$  is the variable value at iteration  $i$ ,  $E$  is the objective function value and  $\Delta$  is a perturbation applied on the values of the variable  $x_i$ .

If objective function at  $x_{i+1}$  is not better than the previous solution, it may be accepted even so, accordingly to an acceptance probability.

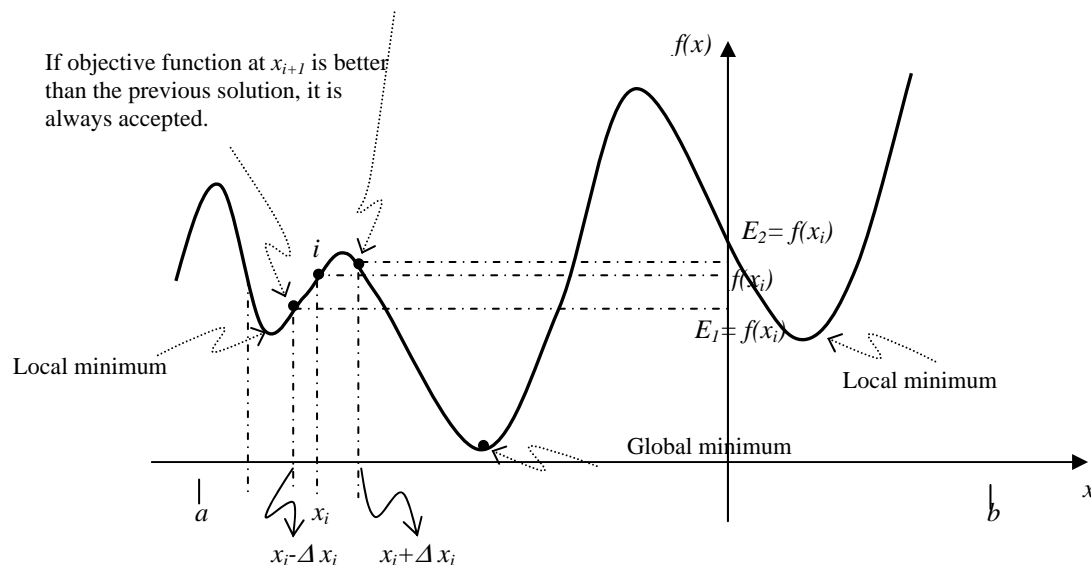

Figure 1: Behavior of the Annealing Algorithm for function minimization with one variable.

The extension for multivariable problems is straightforward as indicated by the pioneer work of [Kirkpatrick \(1983\)](#). A simplified sketch (pseudo-code) of the algorithm implementation is depicted in the following [Figure 2](#).

```

initialization (Current solution at  $x_i$ , current temperature  $T_i$ )
evaluation of the current objective function  $E_i$ .
while stop Criteria is not satisfied
    through perturbation of the current solution  $x_i$ , find a new state  $x_{i+1}$ 
    evaluation of the objective function at new state  $E_{i+1}$ 
    if  $(E_i - E_{i+1}) \leq 0$  then
         $x_i = x_{i+1}$ 
    else
        if  $e^{-\frac{E_i - E_{i+1}}{T_i}} > \text{radom}(0,1)$  then
            this new state is accepted ( $x_i = x_{i+1}$ )
        else
            this state is rejected
        end of if
    end of while
    evaluation of the Stop Criteria
    decrease the Temperature following a cooling schedule
end of while

```

Figure 2: Pseudo-Code for Simulated Annealing Algorithm.

In this paper it was adopted the exponential scheme for the temperature cooling schedule. This is the simplest scheme that assures a convergence to the method since temperature is multiplied by a scaling factor (in this paper 0.85), at each temperature step, that tends to zero.

In the implemented algorithm, the stopping criterion is based on the steady value of the cost function between iterations of the temperature reduction loop. If this value does not change in four temperature reductions, it is assumed that the global minimum was achieved. Several new implementations have been made based on this basic algorithm so there are a large amount of variants in the literature ([Varanelli, 1996](#)). More details about the method can be found in [Dréo \(2003\)](#) or [Weck \(2005\)](#).

### 3 SOME BENCHMARK EXAMPLES

#### 3.1 Example 1 – Optimization of a Four Bar Truss

The structure of a simple four bar truss is optimized by the Simulated Annealing Technique. This example was solved by Haftka (1991) with the Linear Programming Technique. The applied load is  $P=10\text{N}$ , the length is  $L=2,0\text{ m}$ , the Young Modulus of the members is  $E=1.0 \times 10^4\text{ N/m}^2$ . The constraints in the vertical displacement on node 3 is set as  $y_3 < 3.0 \times 10^{-6}L$  and the stress constraint for all member is set as  $\sigma_c < 4.833 \times 10^{-4} E\text{ (N/m}^2\text{)}$  for the compression members and  $\sigma_t > -7.73 \times 10^{-4} E\text{ (N/m}^2\text{)}$  for the tension members. For simplicity the material density is set as  $\rho=1.0\text{ kg/m}^3$ . The sectional areas are treated as the design variables and the allowed range of variation is set from  $0.1\text{ m}^2$  to  $10.0\text{ m}^2$ . Figure 3 shows a sketch for the analyzed truss. In this problem, members 1, 2 and 3 have the same cross sectional area and the last one, the 4<sup>th</sup>, has another cross sectional area, so the optimization problem simplifies to a two design optimization problem. The solution presented in the literature (Haftka, 1991) shows a minimal weight of  $89.57\text{ kg}$  for the design variables  $A_1=A_2=A_3=A_4=9.464\text{ m}^2$ .

In this example, the following parameters were used for the simulations:

Temperature Schedule	Exponential
Initial Temperature	1.0
Reduction Temperature factor	0.85
Maximum Number of iterations	100000
Tolerance for Convergence	1.0E-3

Table 1: Parameters used in the four member truss example with the Simulated Annealing Algorithm.

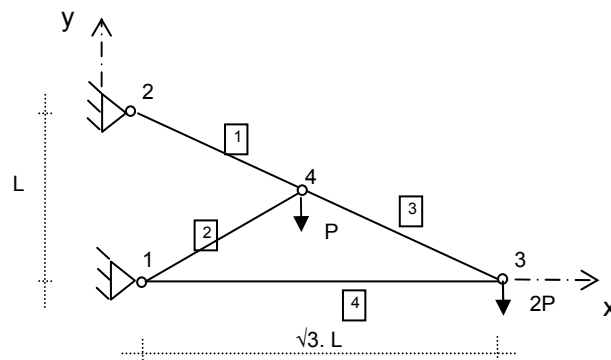

Figure 3: Four member truss sketch.

In the Figure 4, it is shown the results obtained with the Simulated Annealing Technique along the iterations. The final obtained design variables were  $9.4477\text{ m}^2$ . And the final total weight of the truss was  $89.486\text{ kg}$ . Since, in this example, the technique to account for constraints is the penalty technique, only constraints in displacement were slightly violated by  $0.1\%$ . Neither tension nor compression stresses were violated in this example.

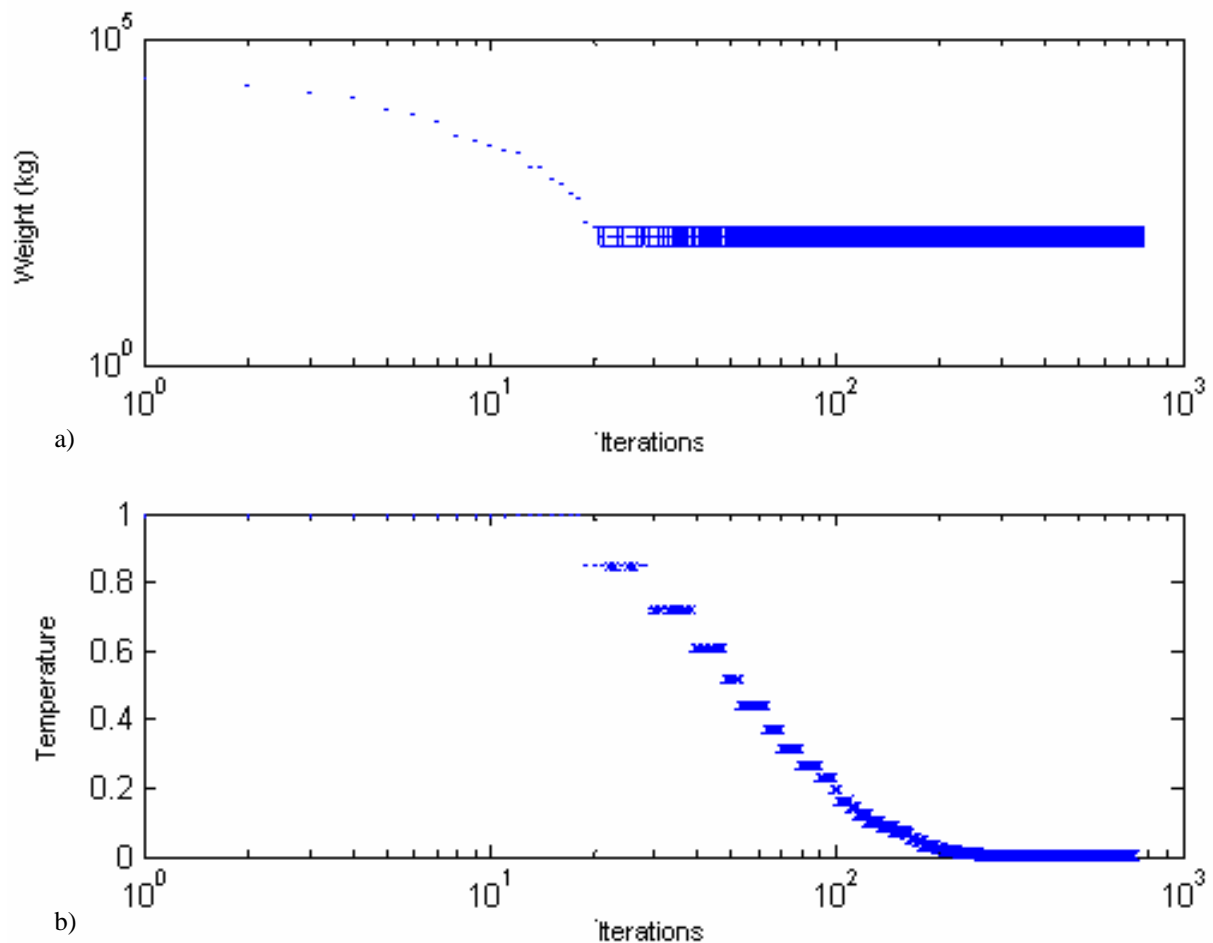

Figure 4: Objective Function Values and Temperature versus iteration for example 1. (a)Objective function (b) Temperature.

The total elapsed time using a Pentium 4 computer with 1 GB RAM and 1.8MHz CPU was about 185 seconds. The total number of function evaluations was 3201. Less than a half of the total number of evaluations (1367) was accepted (uphill moves).

The same problem solved with the Genetic Algorithm Toolbox (Matlab, 2001) presented a final weight of 89.49 kg with the final cross sectional areas of  $A_1=A_2=A_3=9.399 \text{ m}^2$  and  $A_4=9.53 \text{ m}^2$  with a displacement constraint violation about  $10^{-4}$ . And the same problem presents, when solved with the Sequential Quadratic Programming (SQP, Matlab, 2001) technique, the final weight of 89.55 kg and the final cross sectional areas of  $A_1=A_2=A_3=9.462 \text{ m}^2$  and  $A_4=9.463 \text{ m}^2$  with a displacement constraint violation about  $10^{-5}$ .

### 3.2 Example 2 – Optimization of a Ten Member Truss

In this example, the weight of a ten member truss is optimized using the Simulated Annealing Technique. This example was also solved using Sequential Nonlinear Approximate Optimization by Haftka (1991). The applied load at nodes 4 and 2 is  $P=4.448 \times 10^5 \text{ N}$  [100 Kips]. Both horizontal and vertical member length is  $L = 9.144 \text{ m}$  (360 in). The material Young Modulus is  $E=6.8958 \times 10^6 \text{ N/m}^2$  (1 ksi), for all members there is a tension/compression limit constraint of  $|\sigma_c|=|\sigma_t| < 1.724 \times 10^8 \text{ N/m}^2$  (25 ksi), but for the ninth

member, those limits are modified to  $|\sigma_c|=|\sigma_t|<5.171\times 10^8 \text{ N/m}^2$  (75 ksi). The material mass density is set as  $\rho=2.768\times 10^3 \text{ kg/m}^3$  (0.1 lbm/in<sup>3</sup>). All the cross sectional areas are design variables and can range from  $6.452\times 10^{-5} \text{ m}^2$  to  $6.452\times 10^{-3} \text{ m}^2$  (0.1 to 10.0 in<sup>2</sup>). So the problem is a 10 design variable Optimization Problem. Figure 5 shows a sketch of the truss.

The same parameters used in Example 1 in the Simulated Annealing Technique were used in this example. Haftka (1991) indicates the following best solution for this optimization task:  $A_1=5.097\times 10^{-3} \text{ m}^2$  (7.90 in<sup>2</sup>),  $A_2= 6.452\times 10^{-5} \text{ m}^2$  (0.10 in<sup>2</sup>),  $A_3=5.226\times 10^{-3} \text{ m}^2$  (8.10 in<sup>2</sup>),  $A_4=2.516\times 10^{-3} \text{ m}^2$  (3.90 in<sup>2</sup>),  $A_5=6.452\times 10^{-5} \text{ m}^2$  (0.10 in<sup>2</sup>),  $A_6=6.452\times 10^{-5} \text{ m}^2$  (0.10 in<sup>2</sup>),  $A_7=3.472\times 10^{-3} \text{ m}^2$  (5.80 in<sup>2</sup>),  $A_8=3.555\times 10^{-3} \text{ m}^2$  (5.51 in<sup>2</sup>),  $A_9=2.374\times 10^{-3} \text{ m}^2$  (3.68 in<sup>2</sup>),  $A_{10}=9.032\times 10^{-5} \text{ m}^2$  (0.14 in<sup>2</sup>), with a minimum weight of 679.028 kg (1.497 lb).

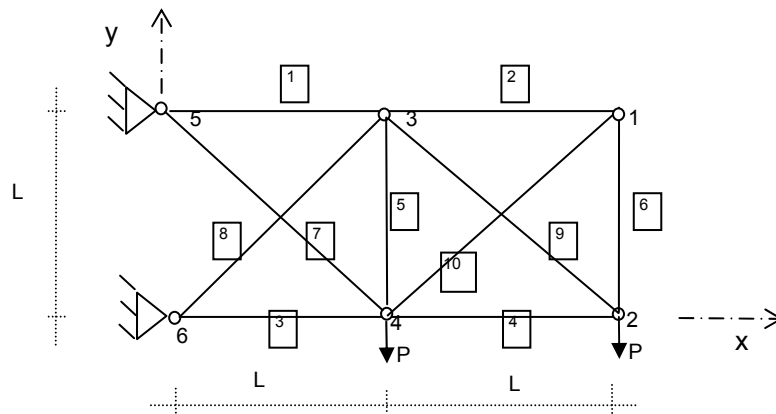

Figure 5: Sketch of the ten member truss.

Figure 6 shows the evolution of the weight and temperature values during iteration. The total elapsed time for this example last 1264 s on the same computer architecture indicated in example 1. The obtained solution with Simulated Annealing was  $A_1=4.759\times 10^{-3} \text{ m}^2$  (7.37 in<sup>2</sup>),  $A_2= 4.00\times 10^{-4} \text{ m}^2$  (0.62 in<sup>2</sup>),  $A_3=5.555\times 10^{-3} \text{ m}^2$  (8.61 in<sup>2</sup>),  $A_4=2.183\times 10^{-3} \text{ m}^2$  (3.38 in<sup>2</sup>),  $A_5=6.458\times 10^{-5} \text{ m}^2$  (0.10 in<sup>2</sup>),  $A_6=6.452\times 10^{-5} \text{ m}^2$  (0.10 in<sup>2</sup>),  $A_7=4.21\times 10^{-3} \text{ m}^2$  (6.52 in<sup>2</sup>),  $A_8=3.08\times 10^{-3} \text{ m}^2$  (4.774 in<sup>2</sup>),  $A_9=2.053\times 10^{-3} \text{ m}^2$  (3.18 in<sup>2</sup>),  $A_{10}=5.658\times 10^{-5} \text{ m}^2$  (0.87 in<sup>2</sup>), with a minimum weight of 693.2 kg (1.5283 lb).

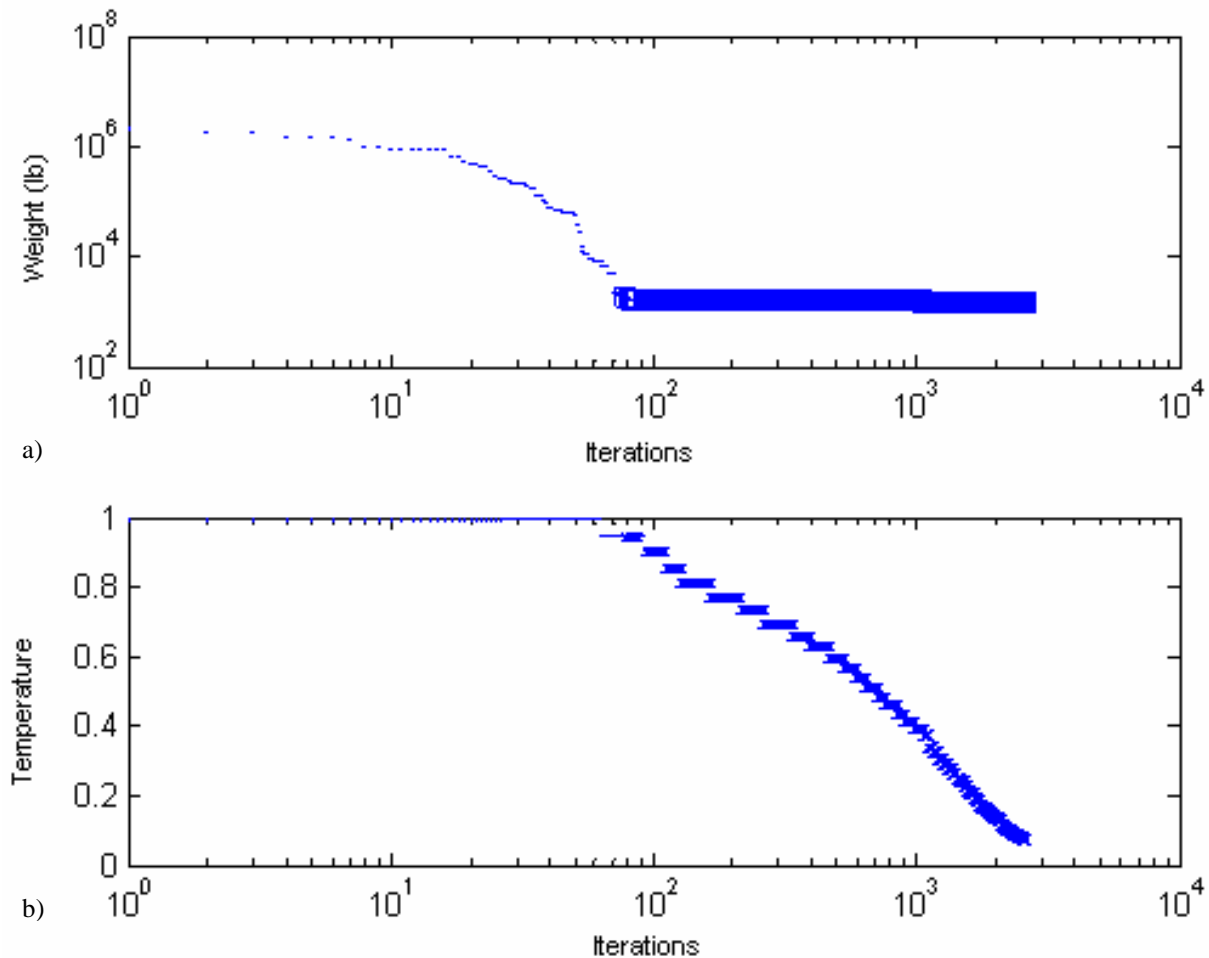

Figure 6: Objective Function Values and Temperature versus iteration for example 2. (a)Objective function. (b)Temperature.

It can be noticed that the results were slightly worse, since the weight was 2.1% greater than the indicated by the literature.

The same problem was solved by Teles (2007) using Genetic Algorithm and the results for the cross sectional areas were  $A_1= 4.623 \times 10^{-3} \text{ m}^2$  (7,16583 in<sup>2</sup>),  $A_2= 6.452 \times 10^{-4} \text{ m}^2$  (1,00383 in<sup>2</sup>),  $A_3= 5.795 \times 10^{-3} \text{ m}^2$  (8,98245 in<sup>2</sup>),  $A_4= 2.192 \times 10^{-3} \text{ m}^2$  (3,39835 in<sup>2</sup>),  $A_5= 8.903 \times 10^{-6} \text{ m}^2$  (0,01381 in<sup>2</sup>),  $A_6= 6.354 \times 10^{-4} \text{ m}^2$  (0,98495 in<sup>2</sup>),  $A_7= 4.485 \times 10^{-3} \text{ m}^2$  (6,95241 in<sup>2</sup>),  $A_8= 2.888 \times 10^{-3} \text{ m}^2$  (4,47655 in<sup>2</sup>),  $A_9= 2.1543 \times 10^{-3} \text{ m}^2$  (3,33849 in<sup>2</sup>),  $A_{10}= 7.872 \times 10^{-4} \text{ m}^2$  (1,22012 in<sup>2</sup>), with a minimum weight of 721.1 kg (1.5897 lb).

Teles (2007) solved the same problem by the SQP algorithm which did not converge. It was reported that this happened due to excessive function evaluations (>1000). Nevertheless, the obtained solution for the cross sectional areas in the last iteration were  $A_1= 5.096 \times 10^{-3} \text{ m}^2$  (7,899 in<sup>2</sup>),  $A_2= 6.452 \times 10^{-5} \text{ m}^2$  (0,10 in<sup>2</sup>),  $A_3= 5.225 \times 10^{-3} \text{ m}^2$  (8,098 in<sup>2</sup>),  $A_4= 2.516 \times 10^{-3} \text{ m}^2$  (3,90 in<sup>2</sup>),  $A_5= 6.452 \times 10^{-5} \text{ m}^2$  (0,100 in<sup>2</sup>),  $A_6= 6.452 \times 10^{-5} \text{ m}^2$  (0,100 in<sup>2</sup>),  $A_7= 3.740 \times 10^{-3} \text{ m}^2$  (5,797 in<sup>2</sup>),  $A_8= 3.558 \times 10^{-3} \text{ m}^2$  (5,5151 in<sup>2</sup>),  $A_9= 2.372 \times 10^{-3} \text{ m}^2$  (3,6763 in<sup>2</sup>),  $A_{10}= 9.123 \times 10^{-5} \text{ m}^2$  (0,1414 in<sup>2</sup>), with a minimum weight of 679.22 kg (1497.43 lb) with displacements constraint violation of  $10^{-6}$ . This result is closer than the previous ones with Annealing and Genetic Algorithm.



### 3.3 Example 3 – Optimization of a Twenty Five Member Truss

This example intends to optimize the weight of the 25 member truss sketched in Figure 7. This truss has groups of members with the same cross sectional area. The 1<sup>st</sup>. group includes just bar No. 1, the 2<sup>nd</sup>. group includes bar 2, 3, 4 and 5. The 3<sup>rd</sup>. group includes bars 6, 7, 8 and 9. The 4<sup>th</sup>. group includes bars 10 and 11, the 5<sup>th</sup>. group includes bars 12 and 13, the 6<sup>th</sup>. group includes bars 14, 15, 16 and 17, the 7<sup>th</sup>. group includes bar 18, 19, 20 and 21 and the last group includes bar 22, 23, 24 and 25. Each of the group member area is allowed to vary together between  $3.226 \times 10^{-5} \text{ m}^2$  to  $2.581 \times 10^{-3} \text{ m}^2$  ( $0.05$  to  $4.0 \text{ in}^2$ ), so this example is an 8 design variable Optimization Problem. The mass density is assumed as  $\rho = 2.768 \times 10^3 \text{ kg/m}^3$  ( $0.10 \text{ lbm/in}^3$ ) and the Young Modulus  $E = 6.895 \times 10^{10} \text{ N/m}^2$  ( $1.0 \times 10^4 \text{ ksi}$ ). The loads are applied as indicated by Table 2.

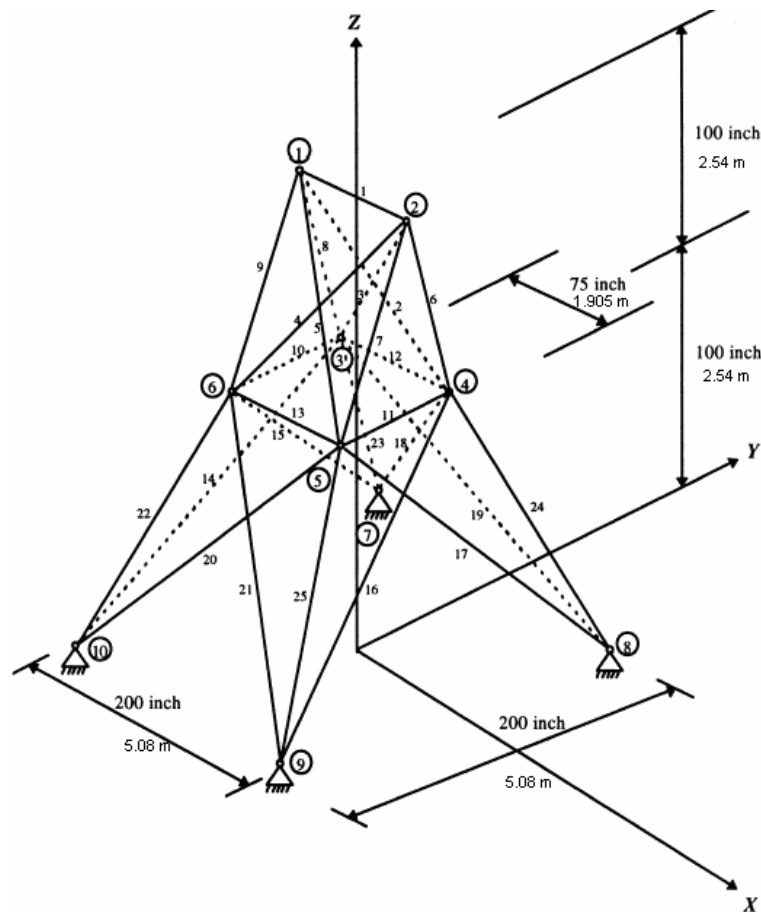

Figure 7: Sketch of the 25 member truss.

Node	Fx	Fy	Fz
1	$4.448 \times 10^3 \text{ N}$ (1000 lbf)	$-4.448 \times 10^3 \text{ N}$ (-1000 lbf)	$-4.448 \times 10^3 \text{ N}$ (-1000 lbf)
2	0.0 N ( 0.0 lbf)	$-4.448 \times 10^3 \text{ N}$ (-1000 lbf)	$-4.448 \times 10^3 \text{ N}$ (-1000 lbf)
3	$2.224 \times 10^3 \text{ N}$ (500.0 lbf)	0.0 N ( 0.0 lbf)	0.0 N ( 0.0 lbf)
6	$2.669 \times 10^3 \text{ N}$ (600.0 lbf)	0.0 N ( 0.0 lbf)	0.0 N ( 0.0 lbf)

Table 2: Applied loads on nodes for the 25 member truss.

Only constraints on displacements and stresses are set. The values are the following:

$|x_1| < 8.89 \times 10^{-3}$  (0.35 in),  $|x_2| < 8.89 \times 10^{-3}$  (0.35 in),  $|y_1| < 8.89 \times 10^{-3}$  (0.35 in),  $|y_2| < 8.89 \times 10^{-3}$  (0.35 in),  $|z_1| < 8.89 \times 10^{-3}$  (0.35 in),  $|z_2| < 8.89 \times 10^{-3}$  (0.35 in),  $|\sigma_c| < 2.758 \times 10^8$  N/m<sup>2</sup> (40.0 ksi),  $|\sigma_t| < 2.758 \times 10^8$  N/m<sup>2</sup> (40.0 ksi). [Rizz appud Pyrz\(2001\)](#) presented the following best solution for this optimization task:  $A_1 = 6.452 \times 10^{-6}$  m<sup>2</sup> (0.01 in<sup>2</sup>),  $A_2 = 1.283 \times 10^{-3}$  m<sup>2</sup> (1.988 in<sup>2</sup>),  $A_3 = 1.93 \times 10^{-3}$  m<sup>2</sup> (2.991 in<sup>2</sup>),  $A_4 = 6.452 \times 10^{-6}$  m<sup>2</sup> (0.01 in<sup>2</sup>),  $A_5 = 6.452 \times 10^{-6}$  m<sup>2</sup> (0.010 in<sup>2</sup>),  $A_6 = 4.413 \times 10^{-4}$  m<sup>2</sup> (0.684 in<sup>2</sup>),  $A_7 = 1.081 \times 10^{-3}$  m<sup>2</sup> (1.676 in<sup>2</sup>),  $A_8 = 1.717 \times 10^{-3}$  m<sup>2</sup> (2.662 in<sup>2</sup>), with a minimum weight of 247.28 kg (545.16 lb).

This example took 1127.8 seconds to reach the optimal solution with the proposed Simulated Annealing Technique with the same previous computer architecture. The obtained solution with Simulated Annealing Technique was  $A_1 = 3.028 \times 10^{-6}$  m<sup>2</sup> (4.694  $\times 10^{-3}$  in<sup>2</sup>),  $A_2 = 2.888 \times 10^{-5}$  m<sup>2</sup> (4.477  $\times 10^{-2}$  in<sup>2</sup>),  $A_3 = 2.345 \times 10^{-3}$  m<sup>2</sup> (3.635 in<sup>2</sup>),  $A_4 = 6.452 \times 10^{-7}$  m<sup>2</sup> (1  $\times 10^{-3}$  in<sup>2</sup>),  $A_5 = 1.286 \times 10^{-3}$  m<sup>2</sup> (1.993 in<sup>2</sup>),  $A_6 = 5.013 \times 10^{-4}$  m<sup>2</sup> (0.777 in<sup>2</sup>),  $A_7 = 1.026 \times 10^{-4}$  m<sup>2</sup> (0.159 in<sup>2</sup>),  $A_8 = 2.527 \times 10^{-3}$  m<sup>2</sup> (3.917 in<sup>2</sup>), with a minimum weight of 210.707 kg (464.53 lb). The total amount of Function evaluation was 9601 with 3628 uphill acceptances. Only displacements constraint violations of about 1% in were noticed for this solution.

The same problem was solved by [Teles \(2007\)](#) using Genetic Algorithm and the results for the cross sectional areas were  $A_1 = 3.99 \times 10^{-5}$  m<sup>2</sup> (0.062 in<sup>2</sup>),  $A_2 = 3.74 \times 10^{-5}$  m<sup>2</sup> (0.058 in<sup>2</sup>),  $A_3 = 2.15 \times 10^{-3}$  m<sup>2</sup> (3.33 in<sup>2</sup>),  $A_4 = 6.73 \times 10^{-5}$  m<sup>2</sup> (0.104 in<sup>2</sup>),  $A_5 = 1.222 \times 10^{-3}$  m<sup>2</sup> (1.894 in<sup>2</sup>),  $A_6 = 4.744 \times 10^{-4}$  m<sup>2</sup> (0.74 in<sup>2</sup>),  $A_7 = 4.66 \times 10^{-5}$  m<sup>2</sup> (0.072 in<sup>2</sup>),  $A_8 = 2.468 \times 10^{-3}$  m<sup>2</sup> (3.825 in<sup>2</sup>), with a minimum weight of 204.04 kg (449.83 lb).

The same problem was solved by [Teles \(2007\)](#) using SQP and the results for the cross sectional areas were  $A_1 = 3.23 \times 10^{-5}$  m<sup>2</sup> (0.05 in<sup>2</sup>),  $A_2 = 3.23 \times 10^{-5}$  m<sup>2</sup> (0.05 in<sup>2</sup>),  $A_3 = 2.43 \times 10^{-3}$  m<sup>2</sup> (3.77 in<sup>2</sup>),  $A_4 = 3.23 \times 10^{-5}$  m<sup>2</sup> (0.05 in<sup>2</sup>),  $A_5 = 1.285 \times 10^{-3}$  m<sup>2</sup> (1.992 in<sup>2</sup>),  $A_6 = 5.015 \times 10^{-4}$  m<sup>2</sup> (0.777 in<sup>2</sup>),  $A_7 = 1.021 \times 10^{-4}$  m<sup>2</sup> (0.158 in<sup>2</sup>),  $A_8 = 2.527 \times 10^{-3}$  m<sup>2</sup> (3.917 in<sup>2</sup>), with a minimum weight of 211.22 kg (465.66 lb).

It is clear that in this case, the results from GA showed better results than SA Technique. This last method (SA) in turn showed better results than the SQP algorithm. In [Figure 8](#) it is shown the behavior of the weight and temperature with iterations.

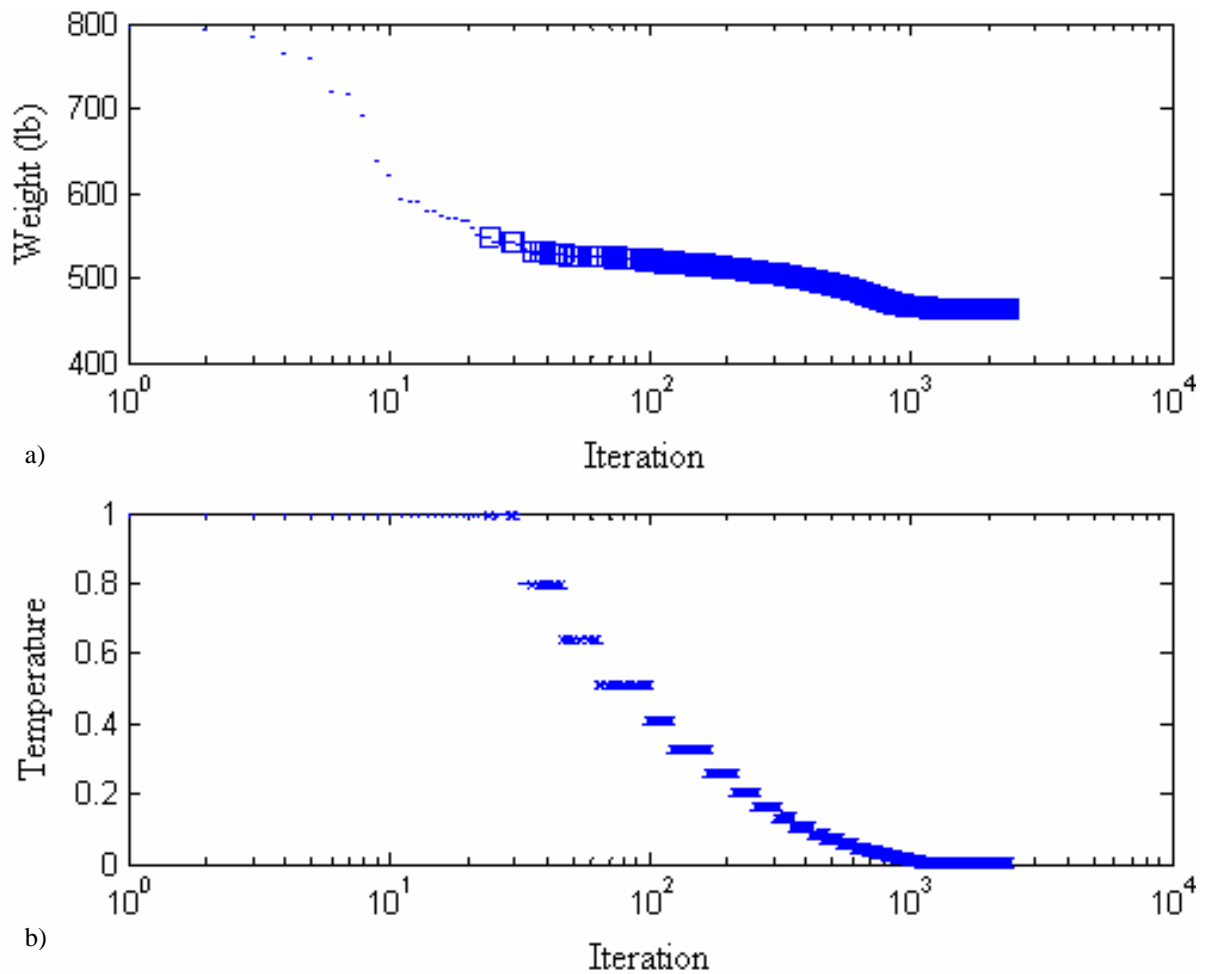

Figure 8: Objective Function Values and Temperature versus iteration for example 3. (a) Objective function. (b) Temperature.

### 3.4 Example 4 – Optimization of a Seventy Two Member Truss

In this example, the weight of a seventy two member truss is optimized. This problem was analyzed by [Erbatur \(2000\)](#) using GA. [Figure 9](#) shows a sketch of the analyzed truss structure.

The mass density is assumed as  $\rho=2.768 \times 10^3 \text{ kg/m}^3$  ( $0.10 \text{ lbm/in}^3$ ) and the Young Modulus  $E= 6.895 \times 10^{10} \text{ N/m}^2$  ( $1.0 \times 10^4 \text{ ksi}$ ). The loads are applied as indicated by [Table 3](#).

Node	Fx	Fy	Fz
1	$2.224 \times 10^4 \text{ N}$ (5000 lbf)	$2.224 \times 10^4 \text{ N}$ (5000 lbf)	$-2.224 \times 10^4 \text{ N}$ (-5000 lbf)

Table 3: Applied loads on nodes for the 72 member truss.

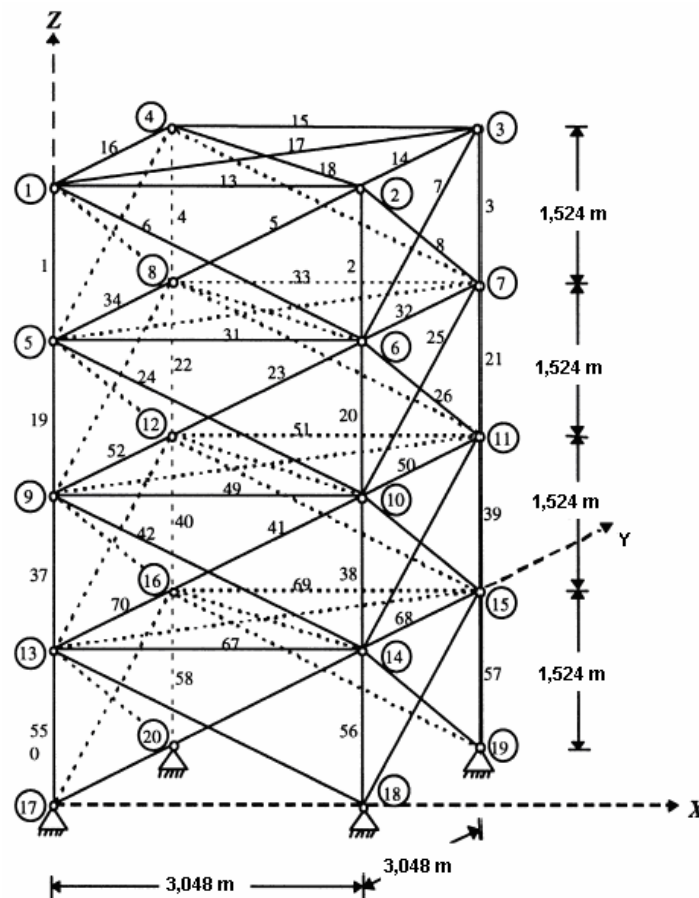

Figure 9: Sketch of the 72 member truss.

Table 4 shows the member groups. There are 16 groups, so this is a 16 design variable optimization problem.

Group	A <sub>1</sub>	A <sub>2</sub>	A <sub>3</sub>	A <sub>4</sub>	A <sub>5</sub>	A <sub>6</sub>	A <sub>7</sub>	A <sub>8</sub>
Member	1-4	5-12	13-16	17-18	19-22	23-30	21-24	35-36
Group	A <sub>9</sub>	A <sub>10</sub>	A <sub>11</sub>	A <sub>12</sub>	A <sub>13</sub>	A <sub>14</sub>	A <sub>15</sub>	A <sub>16</sub>
Member	37-40	42-48	49-52	53-54	55-58	59-66	67-70	71-72

Table 4: Member groups for the 72 member truss.

Constraints on displacements and stresses are set such as in directions  $x$  and  $y$  the displacements on all nodes should not exceed  $6.35 \times 10^{-3}$  m (0.25 in.). Furthermore  $|\sigma_c|$  and  $|\sigma_t| < 1.7237 \times 10^8$  N/m<sup>2</sup> (25 ksi). All member groups cross sectional areas are allowable to assume values greater than  $6.452 \times 10^{-5}$  (0.1 in<sup>2</sup>).

Erbatur(2000) presented the following best solution for this optimization task:  $A_1 = 1.0 \times 10^{-4}$  m<sup>2</sup> (0.155 in<sup>2</sup>),  $A_2 = 3.5 \times 10^{-4}$  m<sup>2</sup> (0.535 in<sup>2</sup>),  $A_3 = 3.1 \times 10^{-3}$  m<sup>2</sup> (0.480 in<sup>2</sup>),  $A_4 = 3.4 \times 10^{-4}$  m<sup>2</sup> (0.52 in<sup>2</sup>),  $A_5 = 3.0 \times 10^{-4}$  m<sup>2</sup> (0.460 in<sup>2</sup>),  $A_6 = 3.4 \times 10^{-4}$  m<sup>2</sup> (0.53 in<sup>2</sup>),  $A_7 = 0.81 \times 10^{-4}$  m<sup>2</sup> (0.12 in<sup>2</sup>),  $A_8 = 1.1 \times 10^{-4}$  m<sup>2</sup> (0.165 in<sup>2</sup>),  $A_9 = 7.5 \times 10^{-4}$  m<sup>2</sup> (1.155 in<sup>2</sup>),  $A_{10} = 3.8 \times 10^{-4}$  m<sup>2</sup> (0.585 in<sup>2</sup>),  $A_{11} = 0.6 \times 10^{-4}$  m<sup>2</sup> (0.1 in<sup>2</sup>),  $A_{12} = 0.6 \times 10^{-4}$  m<sup>2</sup> (0.1 in<sup>2</sup>),  $A_{13} = 11.3 \times 10^{-4}$  m<sup>2</sup> (0.165 in<sup>2</sup>),  $A_{14} = 3.3 \times 10^{-4}$  m<sup>2</sup> (0.505 in<sup>2</sup>),  $A_{15} = 0.7 \times 10^{-4}$  m<sup>2</sup> (0.105 in<sup>2</sup>),  $A_{16} = 1.0 \times 10^{-4}$  m<sup>2</sup> (0.155 in<sup>2</sup>), with a minimum weight of 174.98 kg (545.16 lb).

This example took 1351 seconds to reach the optimal solution with the proposed Simulated

Annealing Technique with the same previous computer architecture. The obtained solution with Simulated Annealing was  $A_1=6.47 \times 10^{-5} \text{ m}^2$  (0.1 in<sup>2</sup>),  $A_2=3.72 \times 10^{-4} \text{ m}^2$  (0.576 in<sup>2</sup>),  $A_3=2.523 \times 10^{-4} \text{ m}^2$  (0.391 in<sup>2</sup>),  $A_4=3.263 \times 10^{-4} \text{ m}^2$  (0.5058 in<sup>2</sup>),  $A_5=3.493 \times 10^{-4} \text{ m}^2$  (0.5414 in<sup>2</sup>),  $A_6=3.408 \times 10^{-4} \text{ m}^2$  (0.5283 in<sup>2</sup>),  $A_7=6.47 \times 10^{-5} \text{ m}^2$  (0.1 in<sup>2</sup>),  $A_8=6.47 \times 10^{-5} \text{ m}^2$  (0.1 in<sup>2</sup>),  $A_9=8.31 \times 10^{-3} \text{ m}^2$  (1.288 in<sup>2</sup>),  $A_{10}=3.67 \times 10^{-4} \text{ m}^2$  (0.57 in<sup>2</sup>),  $A_{11}=6.581 \times 10^{-5} \text{ m}^2$  (0.102 in<sup>2</sup>),  $A_{12}=6.581 \times 10^{-5} \text{ m}^2$  (0.102 in<sup>2</sup>),  $A_{13}=9.626 \times 10^{-4} \text{ m}^2$  (1.492 in<sup>2</sup>),  $A_{14}=3.074 \times 10^{-4} \text{ m}^2$  (0.4764 in<sup>2</sup>),  $A_{15}=6.47 \times 10^{-5} \text{ m}^2$  (0.1 in<sup>2</sup>),  $A_{16}=6.516 \times 10^{-5} \text{ m}^2$  (0.101 in<sup>2</sup>), with a minimum weight of 169.621 kg (373.95 lb). The total amount of Function evaluation was 8035 with 4021 uphill acceptances. Only displacements constraint violations less than 1% in were noticed for this solution. Figure 10 shows the behavior of the Weight and Temperature along iterations.

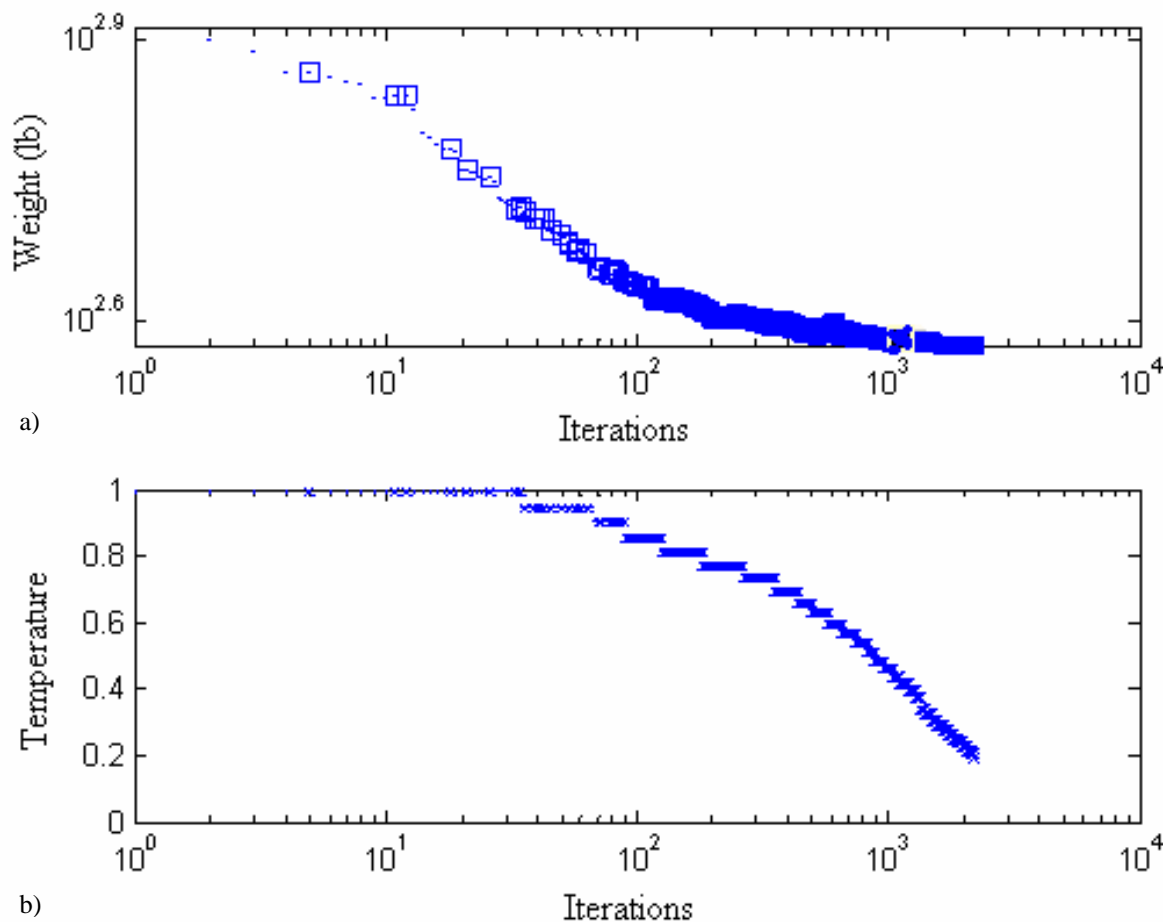

Figure 10: Objective Function Values and Temperature versus iteration for example 4. (a) Objective function. (b) Temperature.

The same problem was solved by Teles (2007) using Genetic Algorithm and SQP. The results for the cross sectional areas and total weight were listed in the Table 5.

Group	A <sub>1</sub>	A <sub>2</sub>	A <sub>3</sub>	A <sub>4</sub>	A <sub>5</sub>	A <sub>6</sub>	A <sub>7</sub>	A <sub>8</sub>
Area m <sup>2</sup> (in <sup>2</sup> )	0.7x10 <sup>-4</sup> (0.109)	3.7x10 <sup>-4</sup> (0.574)	3.2x10 <sup>-4</sup> (0.496)	3.5x10 <sup>-4</sup> (0.543)	3.5x10 <sup>-4</sup> (0.543)	3.4x10 <sup>-4</sup> (0.527)	0.6x10 <sup>-4</sup> (0.093)	0.7x10 <sup>-4</sup> (0.109)
Group	A <sub>9</sub>	A <sub>10</sub>	A <sub>11</sub>	A <sub>12</sub>	A <sub>13</sub>	A <sub>14</sub>	A <sub>15</sub>	A <sub>16</sub>
Area m <sup>2</sup> (in <sup>2</sup> )	7.1x10 <sup>-4</sup> (1.101)	3.4x10 <sup>-4</sup> (0.527)	0.9x10 <sup>-4</sup> (0.14)	0.8x10 <sup>-4</sup> (0.124)	10.2x10 <sup>-4</sup> (1.581)	3.2x10 <sup>-4</sup> (0.496)	0.7x10 <sup>-4</sup> (0.109)	0.7x10 <sup>-4</sup> (0.109)

Total Weight=166.37 kg (366.78 lb)

Table 5: GA Solution for the 72 member truss.

Group	A <sub>1</sub>	A <sub>2</sub>	A <sub>3</sub>	A <sub>4</sub>	A <sub>5</sub>	A <sub>6</sub>	A <sub>7</sub>	A <sub>8</sub>
Area m <sup>2</sup> (in <sup>2</sup> )	6.7x10 <sup>-4</sup> (1.0)	3.9x10 <sup>-4</sup> (0.61)	3.9x10 <sup>-4</sup> (0.61)	5.7x10 <sup>-4</sup> (0.88)	6.7x10 <sup>-4</sup> (1.0)	3.9x10 <sup>-4</sup> (0.61)	3.9x10 <sup>-4</sup> (0.61)	3.9x10 <sup>-4</sup> (0.61)
Group	A <sub>9</sub>	A <sub>10</sub>	A <sub>11</sub>	A <sub>12</sub>	A <sub>13</sub>	A <sub>14</sub>	A <sub>15</sub>	A <sub>16</sub>
Area m <sup>2</sup> (in <sup>2</sup> )	6.7x10 <sup>-4</sup> (1.0)	3.9x10 <sup>-4</sup> (0.61)	3.9x10 <sup>-4</sup> (0.61)	3.9x10 <sup>-4</sup> (0.61)	6.7x10 <sup>-4</sup> (1.0)	4.2x10 <sup>-4</sup> (0.65)	3.9x10 <sup>-4</sup> (0.61)	4.4x10 <sup>-4</sup> (0.68)

Total Weight=260.62 kg (574.57 lb)

Table 6: SQP Solution for the 72 member truss.

In this example the GA performed better than the SA Technique and this last one, in turn, performed better than the SQP Method.

## 4 CONCLUSIONS

This paper described the principles of the Simulated Annealing Technique as a Heuristic tool. This algorithm was implemented in a Matlab Code (Matlab, 2001) and joined with an open source finite element code to perform optimizations. The objective function was the total weight of trusses. It was shown that SA technique may be used as an Optimization tool for weight minimization in trusses structures. The main advantage of this class of algorithms relies in the fact that it is not necessary to evaluate functions gradients.

The developed programs were applied to 4 examples that range from simple trusses to complex ones. It was intended to highlight the behavior of the algorithm in the optimizations. The same problems were compared with results from literature using GA, SQP. One noticed disadvantage in the SA Technique is the slowly convergence rate. In the average, the SA Technique behaved similar to GA and in some cases gave better results than the SQP gradient based method.

## ACKNOWLEDGEMENTS

The authors are grateful for the financial support by the Brazilians Research Councils CAPES and CNPq.

## REFERENCES

- Carrillo, O. J. B., Algoritmo Híbrido para Avaliação da Integridade Estrutural: uma Abordagem Heurística, (*in portuguese*) Doctorial Thesis, Federal University of São Carlos, Brazil, 152p., 2007.
- Coello, C. A.; Christiansen, A. D. Multiobjective optimization of trusses using genetic algorithms, *Computers and Structures*, No.75, pp.647-660, 2000.
- Delyon, B. *Convergence of the Simulated Annealing Algorithm*, LIDS, MIT, Cambridge, 01239, MA, USA, LIDS-P-1808, 16p., august 1988.
- Dréo, J.; Pétrowski, A.; Siarry, P.; Taillard, E., *Metaheuristics for Hard Optimization*, Springer, New York, 2003, 369p.
- Deb, K.; Gulati, S. Design of Truss Structure for minimum weight using genetic algorithm. *Finite Elements in Analysis and Design*, No.37, pp.447-465, 2001.
- Erbatur, Optimal Design of Planar and Space Structures with Genetic Algorithms. *Computers and Structures*, Cambridge, No. 75, p. 209-224, 2000.
- Goffe, W. L.; Ferrier, G. D.; Rogers, J. Global optimization of statistical functions with simulated annealing, *Journal of Econometrics*, No.60, pp.65-99, 1994.
- Hasançebi, O., Erbatır, F. Layout optimisation of trusses using simulated annealing, *Advances in Engineering Software*, V. 33, pp. 681–696, 2002a.
- Hasançebi, O.; Erbatır, F., On efficient use of simulated annealing in complex structural optimization problems, *Acta Mechanica*, No. 157, pp.27- 50, 2002b.
- Ingber, A. L., Very fast simulated re-annealing, *J Mathl. Comput. Modelling*, V. 12, pp. 967-973, 1989.
- Kirkpatrick, S., Gelatt Jr., C. D. and Vecchi, M.P., Optimization by Simulated Annealing, *Science*, V. 220, No. 4598, pp. 671-680, 1983.
- Locatelli, M., Simulated Annealing Algorithms for Continuous Global Optimization: Convergence Conditions, *Journal Of Optimization Theory And Applications*, V. 104, No. 1, pp. 121–133, january, 2000.
- Metropolis, N.; Rosenbluth, A. W.; Rosenbluth, M. N., Teller, A. H. and Teller, E. Equation of state calculation by fast computing machines. *Journal of Chemical Physics*, 21(6):1087–1092, 1953.
- Matlab, The Mathworks Inc., Genetic Algorithm and Direct Search Toolbox/ Optimization Toolbox. 3 Apple Hill Drive. Release 5.0. 2001.
- Pyrz, M.; Zawidska, J., Optimal Discrete Truss Design Using Improved Sequential and Genetic Algorithm. *Engineering Computations*, Bingley, V. 18, n. 8, p. 1078-1090, 2001.
- Haftka, R. A. Gürdal, Z. Elements of structural optimization: Solid mechanics and its applications, Springer, December, 500p., 1991.
- Rajasekaran, S., *On the Convergence Time of Simulated Annealing*, Depart. of Computer & Information Science, Technical Reports (CIS) MS-CIS-90-89, University of Pennsylvania, 19p. 1990.
- Teles, M. L. Avaliação de Desempenho de Algoritmos Genéticos Aplicados à Otimização Paramétrica de Estruturas de Engenharia. (*in Portuguese*), Final Course Work, Mechanical Engineering Department, Porto Alegre, 20p., 2007.
- Varanelli, J. M., *On the Acceleration of Simulated Annealing*, Doctor of Philosophy (Computer Science) University of Virginia, 133p., 1996.
- Weck, O.; Jilla, C. Simulated Annealing: a Basic Introduction, Massachusetts Institute of Technology, *Internal Report*, 44p., 2005.